

Mounted Sprayers



OPTIS & OMNIS

600, 800, 1000 & 1200

www.kuhn.com



be strong, be **KUHN**

OPTIS	600	800	1000
OMNIS	800	1000	1200

KUHN MOUNTED SPRAYERS - SIMPLE AND DURABLE!

SIMPLE, RELIABLE, DURABLE!

OPTIS and OMNIS sprayers are designed for polyculture and livestock farming with a simple and robust structure.

They are equipped with many features as standard to comply with good spraying practices and to meet all standards and regulations.

A WIDE RANGE OF CONFIGURATIONS!

OPTIS and OMNIS sprayers will meet all your needs: their modular design offers a wide range of configurations in terms of models and booms.

	Tank volume (L)	Working width (m)
OPTIS	600, 800 & 1000 L	9 to 16 m
OMNIS	800, 1000 & 1200 L	12 to 15 m





ROBUST!

ONE-PIECE MACHINE-WELDED FRAME

- One-piece structure design for maximum strength and long life
- Piston-diaphragm pump with rear-mounted position for a long transmission, with easy coupling and facilitated access.

PROTECTED TANK

- Secured by a steel strap, the tank is unaffected by movements and perfectly protected.



AUTOMATIC COUPLING

- Makes attachment quick and easy
- Easy coupling of connections and transmission

EASY TO USE...

Intuitive setting up

Comprehensive setting up panel

- Excellent accessibility! Valves are grouped together on an ergonomic panel to avoid handling errors
- Only 3 main valves (1 on OPTIS)
- Reduced preparation time with external suction and 5 m filling pipe (optional on OPTIS)
- External delivery (not available on OPTIS)



Accurate regulation

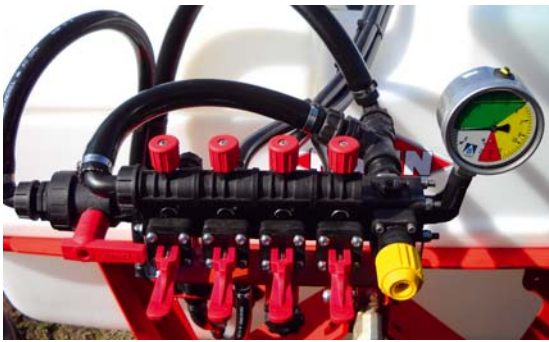

Constant Pressure & DPM

- Manual section opening/closing
- Manual general opening
- Pressure setting on the support (DPM only)
- Support accessible from the tractor



DPF box

KUHN Electronics
INNOVATIVE FARMING



BUS CAN DPS box

DPME (Output Proportional to Electric Motor)

- Compact control unit in the cab: work comfort, safety and accuracy guaranteed!
- Sequential section opening/closing (Independent on OPTIS - DPF)
- Electric general opening
- Pressure setting from the cab
- Hydraulic function control (OMNIS - DPS)



DPAE RPB: comfort and simplicity

RPB unit on OMNIS sprayers only

- The RPB unit automatically adapts the output to the speed of the tractor.
- Selection of hydraulic boom functions
- Permanent display of output (L/ha), speed and pressure
- Pressure alarms, tank low alarms, etc.

...SIMPLE FOR WORK



Booms with manual folding



Steel booms from 2 to 16 m (OPTIS sprayer only)

- Their tried-and-tested design provides robustness and long life even under intensive conditions!
- 2 or 3 arms: quick and simple rear folding
- High-strength enamelled steel
- Spring-loaded safety devices
- Manual or hydraulic winch optional (RPL and RJP2 booms 9 to 16 m only)
- Suspension and frame locking optional (RPL and RJP2 booms 9 to 16 m only)
- Hydraulic tilt corrector (optional) (RJP2 only)



Booms with hydraulic folding



Galvanised Steel Booms from 12 to 15 m (OMNIS sprayers only)

- No need to leave the cab! Folding and unfolding is controlled from the regulation unit, irrespective of kinematics (DPS or RPB)
- Galvanised steel with high resistance to corrosion
- TRAPEZIA suspension ensures perfect boom tracking in relation to the ground (link rod and automatic mechanical tilt corrector)
- Hydraulic lifting as standard
- Hydraulic tilt corrector and frame locking optional





DESIGNED FOR SPRAYING DOWN TO THE SMALLEST DETAILS!



25-LITRE CHEMICAL INDUCTION BOWL (AS STANDARD ON OMNIS SPRAYERS)

Equipped with a rinsing pipe and a bottle rinser, it is used to incorporate the plant protection products into the main tank quickly and safely.



RINSING TANK (AS STANDARD ON OMNIS SPRAYERS)

Fully integrated into OPTIS and OMNIS sprayers, with a capacity of 100 litres. The central rotary washer rinses the main tank quickly and efficiently.



AUTOMATIC COUPLING

Equipped with a three-point coupling triangle and a stand, it considerably reduces attachment times and facilitates equipment connection.



EXTERNAL CLEANING KIT

To clean the sprayer in the field, an automatic 1.5 m hose reel with manual spray gun is positioned near the boom.

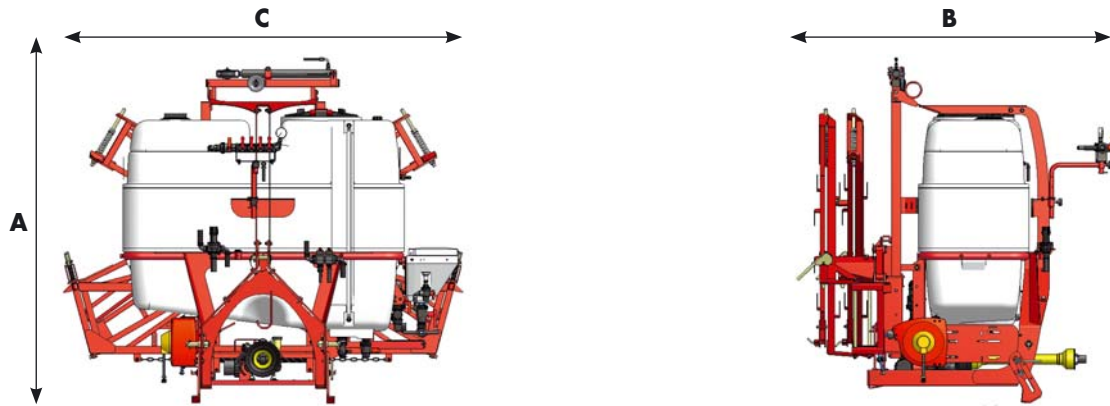

Model	OPTIS 600	OPTIS 800	OPTIS 1000	OMNIS 800	OMNIS 1000	OMNIS 1200
Nominal tank capacity (L)	600	800	1000	800	1000	1200
Actual tank capacity (L)	635	850	1058	850	1080	1260
Rinsing tank (L)	100 – optional			100 – as standard		
Pump (L/min)	PM 75-125-165					
Boom type	Steel, manual folding			Galvanised steel, hydraulic folding		
Boom width (m)	2 to 16			12 to 15		
Incorporator with bottle rinser (L)	25-litre – optional			25-litre – as standard		
Tank rotary washer	◇			◆		
Setting up	Manuset					
Regulation	Constant pressure	◆			-	
	DPM	◇ (DPF)			◆ (DPS)	
	DPAE	-			◇	
Dimensions:	OPTIS 800 RPL 12	OPTIS 800 RJP2 15	OMNIS 1000 RHX 15			
Height A (m)	1.90	1.95	3.20			
Length B (m)	1.70	1.85	1.70			
Width C (m)	2.35	2.52	2.55			
Unladen weight (kg)	338	457	655			

◆ standard equipment ◇ optional equipment - unavailable

Standard equipment:

Rear road signaling equipment and identification plates (according to model and country) - Filtering strainer - Two sets of filters for suction and sections - Universal drive



OPTIS OMNIS DELTIS ALTIS 2 PF

KUHN MOUNTED SPRAYERS IN BRIEF

Technical specifications

	OPTIS/OMNIS	DELTIS	ALTIS 2	PF
Tank capacity (L)	600/800/1000/ 1200	1000/1200	1500/1800/2000	1000/1500
Boom width (m)	9 to 16	14 to 24	14 to 28	-
Regulation	PC / DPM / DPME / DPAE	DPME/DPAE		-
Boom lifting system	Fixed / Hydraulic sliding mast	OPTILIFT parallelogram		-
Boom suspension	◇	TRAPEZIA or EQUILIBRA		-
Product incorporator	◇	◆	◆	◇
Rinsing tank	◇	◆	◆	◆

◆ standard equipment ◇ optional equipment - equipment unavailable

OPTIS / OMNIS

DELTIS

ALTIS 2

PF



For more information about your nearest
KUHN dealer, visit our website
www.kuhn.com



Visit us
on our YouTube channels.



www.kuhn.com

Your KUHN dealer

KUHN BLANCHARD SAS

24 rue de Nantes - 44680 CHÉMÉRÉ - FRANCE

KUHN NORTH AMERICA, INC.

1501 West Seventh Avenue - P.O BOX 0167 -
Brodhead, WI 53520 - USA

KUHN FARM MACHINERY PTY. LTD

313-325 Foleys Road - Deer Park, VIC, 3023 - AUSTRALIA

KUHN FARM MACHINERY (U.K.) LTD

Stafford Park 7 - GB TELFORD/ SHROPS TF3 3BQ

Information given in this document is only for information purposes and is non-contractual. Our machines are in compliance with regulations in force in the country of delivery. In our literature, and for improved illustration of certain details, some safety devices may not be in operating position. When operating these machines, these devices must be in position in accordance with the requirements indicated in the operator's manuals and assembly manuals. Respect the tractor gross vehicle weight rating, its lift capacity and maximum load per axle and tyres. The tractor front axle load must always comply with the regulations of the country of delivery (In Europe, it must reach minimum 20 % of the tractor net weight). We reserve the right to change any designs, specifications or materials listed without further notice. Machines and equipment in this document can be covered by at least one patent and/or registered design. Trademarks cited in this document may be registered in one or several countries.

You will also find
KUHN on

